

REV.  
B

SAE AS117001  
THRU AS117040

FEDERAL SUPPLY CLASS  
5305

RATIONALE

THIS DOCUMENT HAS BEEN DETERMINED TO CONTAIN BASIC AND STABLE TECHNOLOGY WHICH IS NOT DYNAMIC IN NATURE.

STABILIZED NOTICE

THIS DOCUMENT HAS BEEN DECLARED "STABILIZED" BY THE E-25 TECHNICAL COMMITTEE AND WILL NO LONGER BE SUBJECT TO PERIODIC REVIEWS FOR CURRENCY. USERS ARE RESPONSIBLE FOR VERIFYING REFERENCES AND CONTINUED SUITABILITY OF TECHNICAL REQUIREMENTS. NEWER TECHNOLOGY MAY EXIST.

NOTICE

THE INITIAL SAE PUBLICATION OF THIS DOCUMENT WAS TAKEN DIRECTLY FROM U.S. MILITARY STANDARD AN117001 THRU AN117040 REV. 1, NOTICE 1. THIS SAE STANDARD MAY RETAIN THE SAME PART NUMBERS ESTABLISHED BY THE ORIGINAL MILITARY DOCUMENT.

ANY REQUIREMENTS ASSOCIATED WITH QUALIFIED PRODUCTS LISTS (QPL) MAY CONTINUE TO BE MANDATORY FOR DOD CONTRACTS. REQUIREMENTS RELATING TO QPLS HAVE NOT BEEN ADOPTED BY THE SAE FOR THIS STANDARD AND ARE NOT PART OF THIS SAE DOCUMENT.

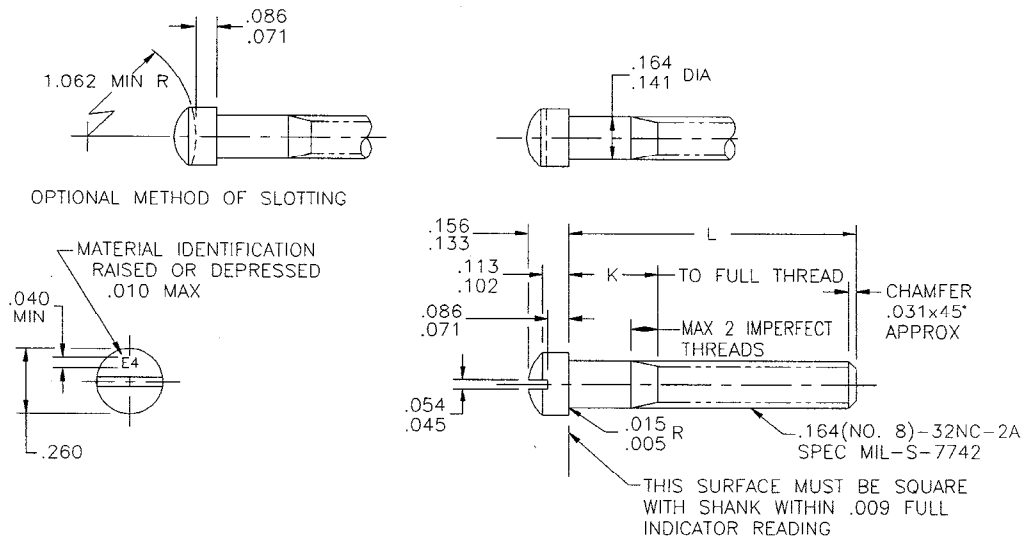
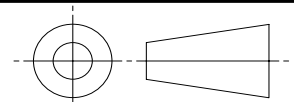

FIGURE 1 - SCREW

SAE values your input. To provide feedback on this Technical Report, please visit <http://www.sae.org/technical/standards/AS117001B>

THIRD ANGLE PROJECTION



CUSTODIAN: E-25

**SAE Aerospace**  
An SAE International Group

**AEROSPACE STANDARD**

SCREW - OVAL FILLISTER HEAD, .164-32

**SAE AS117001  
THRU AS117040  
SHEET 1 OF 2**

**REV.  
B**

SAE Technical Standards Board Rules provide that: "This report is published by SAE to advance the state of technical and engineering sciences. The use of this report is entirely voluntary, and its applicability and suitability for any particular use, including any patent infringement arising therefrom, is the sole responsibility of the user."

SAE reviews each technical report at least every five years at which time it may be reaffirmed, revised, stabilized or cancelled. SAE invites your written comments and suggestions.

ISSUED 2000-08 REAFFIRMED 2005-05 REVISED 2011-08 STABILIZED 2012-02